

# GM 1060

SU-8-negative tone photo-epoxy  
for **layers from 6.0 to 50 $\mu$ m**



## Technical Datasheet



**Gersteltec Sarl.**  
Générale Guisan 26,  
1009, Pully  
Switzerland

Switzerland / Israel / Taiwan

**Contact:** Dr. Moshe Judelewicz  
General Manager

**Phone:** +41 79 564 34 23

**Fax:** +41 21 728 35 83

**Email:** [Moshe@gersteltec.ch](mailto:Moshe@gersteltec.ch)

**Web Site:** [www.gersteltec.ch](http://www.gersteltec.ch)

## General information

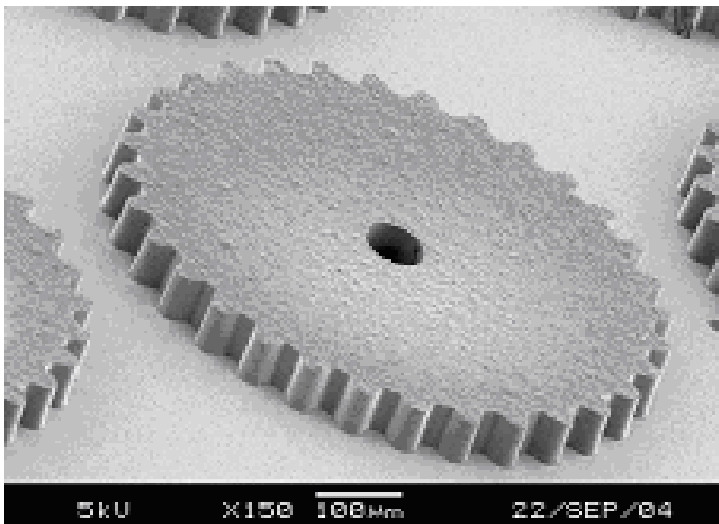

SU-8 is an epoxy based, chemically amplified resist system with excellent sensitivity and high aspect ratios. The primary applications are Micro-fabricated Mechanical Structures (MEMS) and other Microsystems.

Examples are sensors, micro-fluidic components, electronic coils, inkjet print head nozzles, multi-chip modules, actuators, LCD spacers and moulds for plastic, stamps for hot embossing and electroplating.

### Datasheet parts...

- 1 / Schematics of the process
- 2 / Process description
- 3 / Process parameters
- 4 / Processing GM1060 – Overview
- 5 / Typical processes (6 $\mu$ m, 10 $\mu$ m, 15 $\mu$ m, 20 $\mu$ m, 25 $\mu$ m and 50 $\mu$ m)
- 6 / Troubleshooting

**1 / Schematics of the process**

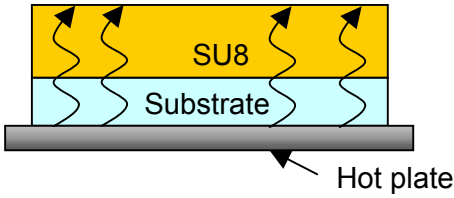

**Step 1:**

- Spin-coating
- Relaxation time to improve uniformity
- Pre-Bake to evaporate solvent (GBL)

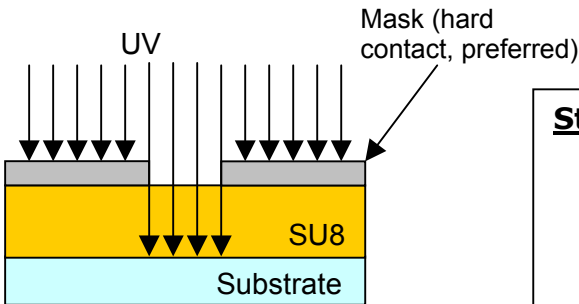
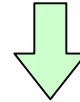

**Step 2:**

- Exposure  
→ with a hard contact preferred to improve exposition homogeneity and side-wall verticality, and keep a clean mask.

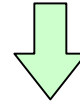

Chemical amplification initiated

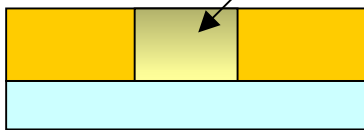

**Result of Step 1:** exposure has only initiated chemical amplification, but the cross-linking reaction is really slow / impossible at room temperature.

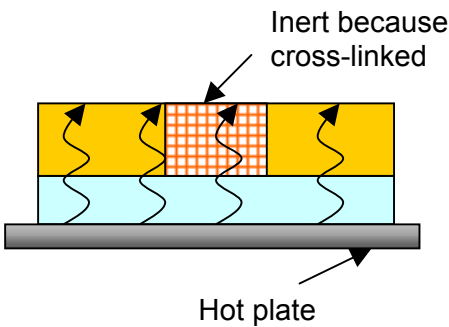
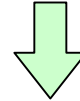

**Step 3:** ... this process is enhanced by a thermal treatment, called Post Exposure Bake (PEB).

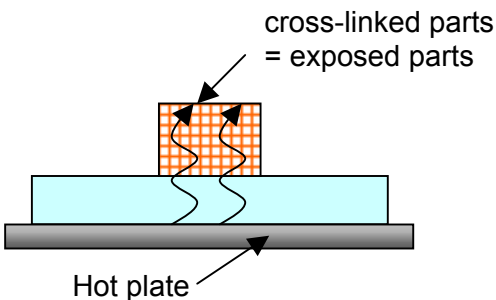
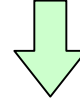

**Step 4:**

- Development with PGMEA\* + Rinse with Isopropanol
- Possible Hard Bake if any relaxation of the material is required (to eliminate some cracks or unstuck parts).

\*PGMEA: Propylene glycol methyl ether acetate

## 2 / Process description

### A typical SU-8 process consists of

- Substrate preparation (dehydration, cleaning...)
- Spin-coating
- Relaxation time to improve the surface uniformity
- Soft Bake
- Exposure to initiate the cross-linking
- Post Exposure bake (PEB), to cross-link exposed regions.
- Development
- Rinse & dry
- Hard Bake (or curing-optional)
- Imaged material (optional: in case of moulding)
- Remove (optional: in case of moulding)

(in chronological order)

- Put the **substrate** in an oven at a minimum temperature of 130 °C during at least 20 minutes to remove adsorbed water from the substrate surface. Alternatively use an oxygen plasma for 7 min at 500 Watts in a Microwave plasma reactor. This should increase the temperature inside the plasma chamber above 80°C after the 2 first minutes. Standard HMDS procedure is not recommended for GM 10series on SiO<sub>2</sub> based wafers.
- **Spin-coat** the resist after cooling down the substrates, at the wanted speed level during 40 seconds. The acceleration and deceleration ramps should be about 100 rpm/s to avoid any contamination of the chuck and the pins by the SU-8. Otherwise, some resist on the vacuum system should damage your spin coat system.

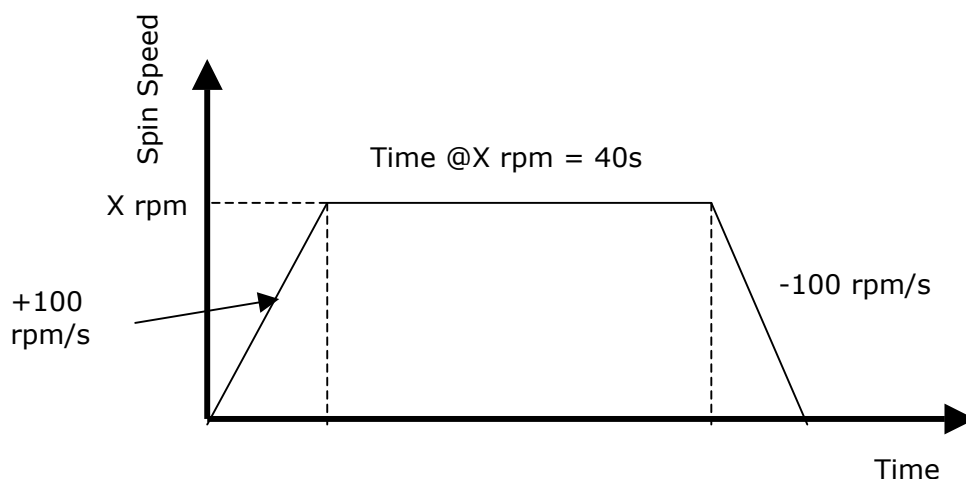

- **Relax (optional)** the resist from 30 min up to 1 hour, depending on the resist thickness. If there are some bubbles just after spin-coating they can be burst using a clean and thin tip. The created hole should be removed during the required time. Finally this relaxation time should improve the uniformity of the layer, and evaporate some portion of solvent.

- **Softbake** the coated substrate in two steps. All the temperature ramps should be about 2°C/min. Firstly increase the temperature from room temperature up to 65°C. Note that for you can even start from 50°C. Then let the substrates at 65°C from 5 to 10min (depending on the resist thickness). The temperature can be then increased up to 95°C where the wafers should be let as much time as necessary that, when holding them with some tweezers there are not printed on the SU-8 layer! Then you can switch off the power or decrease temperature until they reach the room temperature.

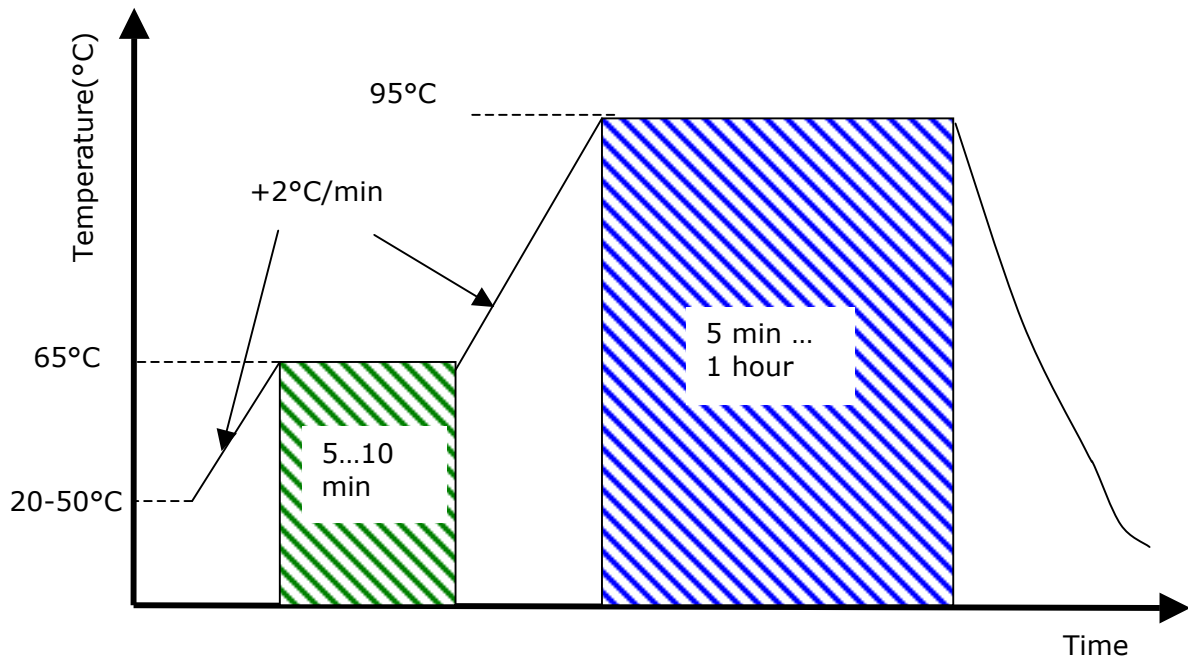

- **Expose** the coated substrate with the mask. This exposure dose adjusts the negative wall profile whom slope is closed to 90°. Have a look on the exposure curve to choose as a function of your thickness the dose that give not any cracks, un-sticking or "stairs effect".  
Note: Exposure doses refer to i-line (365nm). A standard mask aligner with a 350W Hg light source has approx. 6-15 mW/cm<sup>2</sup> i-line intensity, while in many cases 20-30 mW/cm<sup>2</sup> are measured meeting the total (g-, h- and i-line) intensity!

*Ideally* you should try some multiple exposure around the given exposure dose on the Exposure curve. In fact your results may not be exactly the same because of the UV lamp parameters. So you have to optimise this exposure dose parameter simply because your mask aligner is probably not the same than our.

- **Delay time:** Keep the coated substrate at room temperature after the exposure for at least 10 minutes. In this delay time some chemical species will diffuse on the exposed parts giving more homogeneity on the amplification phenomenon.
- **Post Exposure Bake (PEB):** after the delay bake the coated substrate at the same temperature profile than for the Soft Bake. (Because this step is very temperature critical, oven baking is not recommended).  
This step accelerates the cross-linking of the exposed areas making them insoluble in the developer.

- **Develop** in PGMEA. When the structure is through-developed (cleared), add another 10% of the time in a cleaned bath of the total development time to finalize the side wall profile.

**Rinse** with Isopropanol. Once there is not any more white traces the development is then finished. Unfortunately, if you add even more than a few seconds, the SU-8 layer that should be unsticking from the substrate.

**Dry** the wafers just letting them at the ambient air, on a wet bench with an appropriate air flow (exhaust).

- **Hard-bake (optional)** the coated substrate if after drying there are some unstuck SU-8 or cracks. Only the smallest cracks (<5 µm) will be totally removed after this step.

### Optional...

- **Imaged material** (optional: in case of moulding): deposition of you material by sputtering, electrodepositing...
- **Remove SU-8:** using the Gersteltec SU-8 striper

## 3 / Process parameters

GM1060 (60/40)

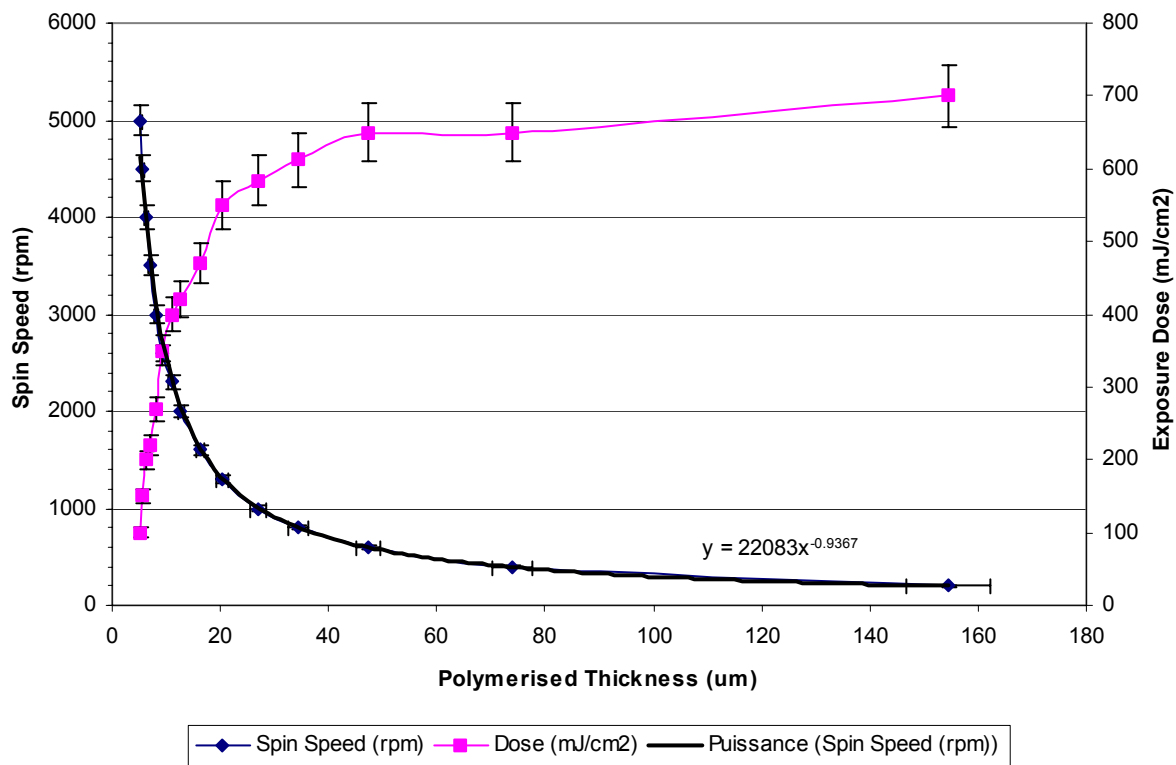

## 4 / Processing GM1060 - Overview

<b>1/ Substrate preparation</b>	Oxygen plasma at 500 W for 7 min (for some new wafers). Otherwise please refer to another method...
<b>2/ Spin coating</b>	Tested from 200 to 5000 rpm with ramps as following... <ul style="list-style-type: none"> <li>- 0 to X rpm with an acceleration =100 rpm/s</li> <li>- at X rpm during 40 s</li> <li>- X rpm to 0 with a deceleration =100 rpm/s</li> </ul>
<b>Resist thickness (µm)</b>	From 5.3 to 151µm but only up to 50 with a good repeatability
<b>3/ Relaxation time</b>	30 min ... 1 hour
<b>Pre-bake or Soft-bake</b>	Temperature ramps... <ul style="list-style-type: none"> <li>- 20-50°C to 65°C at 2°C/min</li> <li>- Stay at 65°C for 5 ... 10min</li> <li>- Go from 65°C to 95°C at 2°C/min</li> <li>- Stay at 95°C for 5min ... 1hour</li> <li>- Decrease up to room temp. (about 2°C/min)</li> </ul> Time dependent on resist thickness and substrate shape.
<b>4/ Exposure Broadband or g, h, i (mJ/cm<sup>2</sup>)</b>	i-line (365 nm) exposure dose
<b>Typical Exposure dose* (mJ/cm<sup>2</sup>)</b>	100 ... 700 Dose dependent on resist thickness and substrate shape
<b>5/ Post Bake Time (Hot plate Temperature)</b>	Temperature ramps... <ul style="list-style-type: none"> <li>- 20-35°C to 65°C at 2°C/min</li> <li>- Stay at 65°C for 5 ... 10min</li> <li>- Go from 65°C to 95°C at 2°C/min</li> <li>- Stay at 95°C for 10 ... 30 min</li> <li>- Decrease up to room temp. (about 2°C/min)</li> </ul>
<b>6/ Delay time</b>	10 min
<b>7/ Developer</b>	<ul style="list-style-type: none"> <li>- PGMEA, used in baths ("old" + "new")</li> </ul> Time in these baths is depending on resist thickness, mask patterns and substrate shape. <ul style="list-style-type: none"> <li>- + Isopropanol to clean</li> <li>- Evaporation of Isopropanol at the ambient air</li> </ul>
<b>8/ Hard Bake (optional)</b>	135°C in an oven for 2 hours ramps should be... <ul style="list-style-type: none"> <li>- relatively progressive to go up to 135°C (2°C/min)</li> <li>- cooling down up to room temperature "naturally" (without cooling source).</li> </ul>
<b>9/ Moulding</b>	Imaged material
<b>Remover (Stripper)</b>	Stripper Gersteltec

\* i-line (365 nm) exposure dose. A standard mask aligner with a 350W Hg source has approx. 6-15 mW/cm<sup>2</sup> i-line intensity, in many cases 20-30 mW are measured meeting the total (g-, h- and i-line) intensity!

All our test have been done with a MA6 mask aligner from Karl Suss with a 250W Hg lamp and, with intensity of 10.0 mW at the wafer emplacement.

## 5 / Typical processes (6 $\mu\text{m}$ , 10, 15, 20, 25 and 50 $\mu\text{m}$ )

Firstly, the wafer preparation should be as mentioned previously (Oxygen plasma at 500W for min 7min (for some cleaned wafers yet)...).

Thickness	6 $\mu\text{m}$	10 $\mu\text{m}$	15 $\mu\text{m}$	20 $\mu\text{m}$	25 $\mu\text{m}$	50 $\mu\text{m}$
<b>Spin coating 40s at ...</b>	4120 rpm	2555 rpm	1745 rpm	1335 rpm	1080 rpm	565 rpm
<b>Relax. Time*</b>	5 min	5 min	10 min	10 min	10 min	15 min
<b>Pre-bake</b>	5 min @65°C, 5 min @95°C	5 min @65°C, 30 min @95°C	10 min @65°C, 35 min @95°C	10 min @65°C, 35 min @95°C	10 min @65°C, 40 min @95°C	10 min @65°C, 1hour @95°C
<b>Typical Exposure dose mJ/cm<sup>2</sup></b>	200 mJ/cm <sup>2</sup>	400	450	550	580	650
<b>Post-Bake</b>	5 min @65°C, 15 min @95°C	5 min @65°C, 20 min @95°C	10 min @65°C, 30 min @95°C	10 min @65°C, 30 min @95°C	10 min @65°C, 30 min @95°C	10 min @65°C, 30 min @95°C
<b>Delay time</b>	10 min	10 min	10 min	10 min	10 min	10 min
<b>Develop** in PGMEA</b>	1 min	1 min 30 s	2 min	2 min 30 s	3 min	4 min
<b>Hard Bake (option)</b>	2h @135°C	2h @135°C	2h @135°C	2h @135°C	2h @135°C	2h @135°C

**Note:** our clean room parameters are 20.5°C ( $\pm 0.1^\circ\text{C}$ ) with 45% ( $\pm 1$  point) of relative humidity.

\*These relaxation time are as a function of the uniformity required for your process.

\*\*These Development times are an example which depends on resist thickness, shape / geometry of the structures.

## 6 / Troubleshooting

- ❑ **Cracks:** these drawbacks appear as a function of the exposure dose, temperature ramps taken and Pre-bake time. Try to increase the exposure dose range by some x10 mJ/cm<sup>2</sup>, if you want to try multiple exposure. Consequently, you will see the quality of the surface changing.
- ❑ **White traces after development:** This is only because there is still some unexposed SU-8 not totally developed. In fact unexposed SU-8+Isopropanol makes a white complex that you can find on your wafers. In the other side, just pay attention to not develop to much time. Otherwise you could unstuck the SU-8 layer from the substrate.

## Appendix

Our machines...:

- Spin-coating: RC-8 from Karl Suss
- Mask aligner: MA6 mask aligner from Karl Suss with a 250W Hg lamp and, with intensity of 10.0 mW at the wafer emplacement.
- Hotplates from Karl Suss.
- Thickness measurements: AlphaStep 500.



### GM1060 (60/40)

